

Air8000开发板/参考设计

REVISION RECORD			
LT#	ECO NO.	APPROVED	DATE

- 1,本原理图为合宙Air8000官方开发板原理图;
- 2,大家也可以直接拿开发板作为参考原理图使用;
- 3,由于是开发板原理图,所以做了一些冗余设计,不需要可忽略;
- 4,典型外设上,比如LCD,请根据自己选择的型号进行设计;
- 5,Air8000 LuatOS二次开发,尤其是GPIO的使用,请务必先看Docs资料;
- 6,GPIO使用注意事项:
<https://docs.openluat.com/air8000/luatos/hardware/design/gpio/>
- 7,更多资料,参见Docs资料连接 www.air8000.cn
- 8,与合宙其它Air780E系列不太一样处理的地方是, Air8000默认IO电平(VDD_EXT)改为了3.3V,不再是1.8V,更方便绝大部分场景下的使用;
- 9,注意!共两页!第二页是以以太网(RJ45)和CAN接口参考设计,不要忘记打开;

必读!必读!必读!

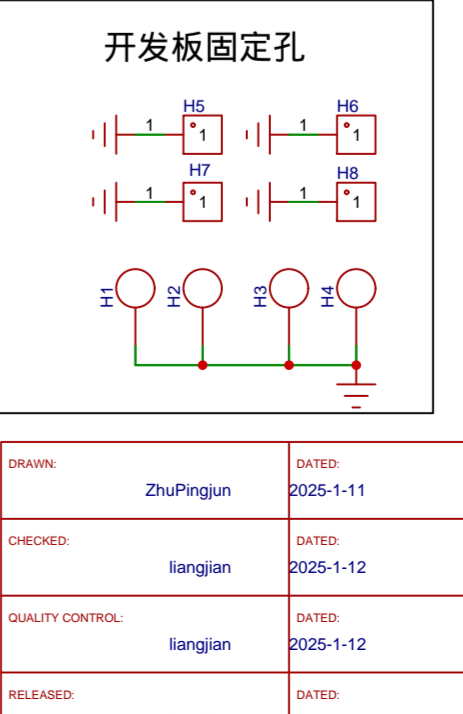
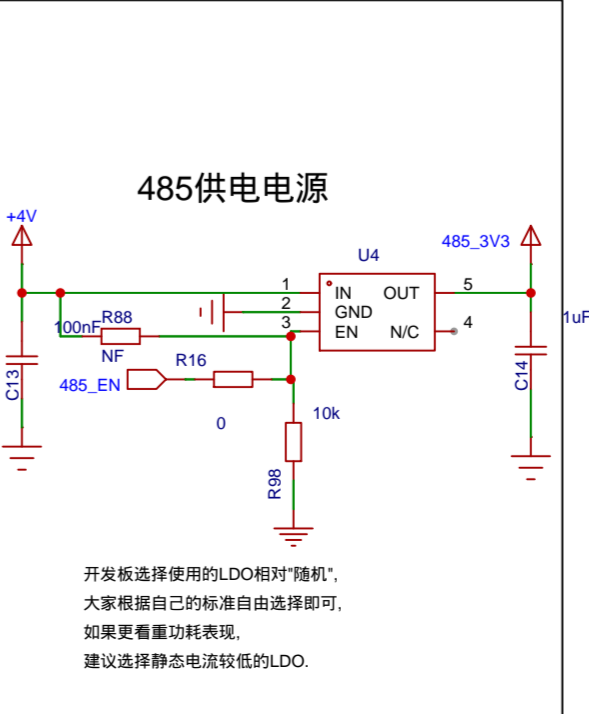
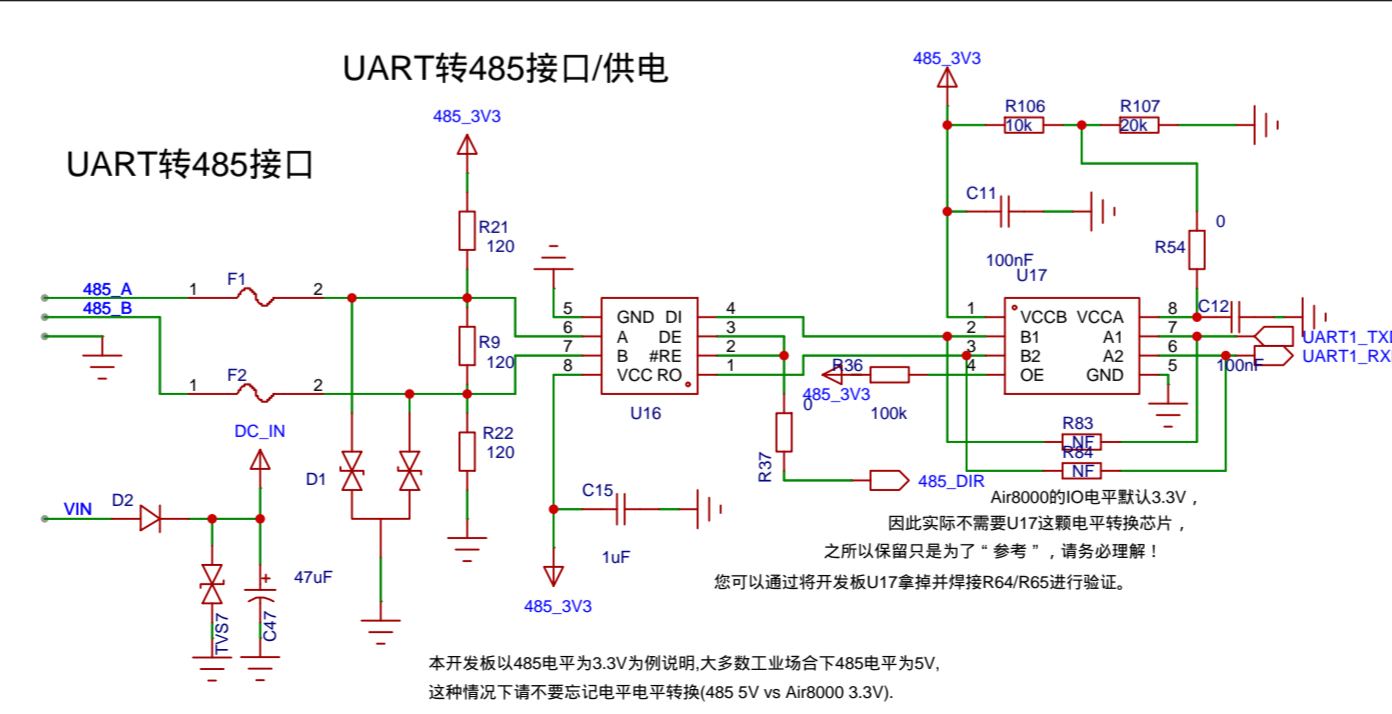
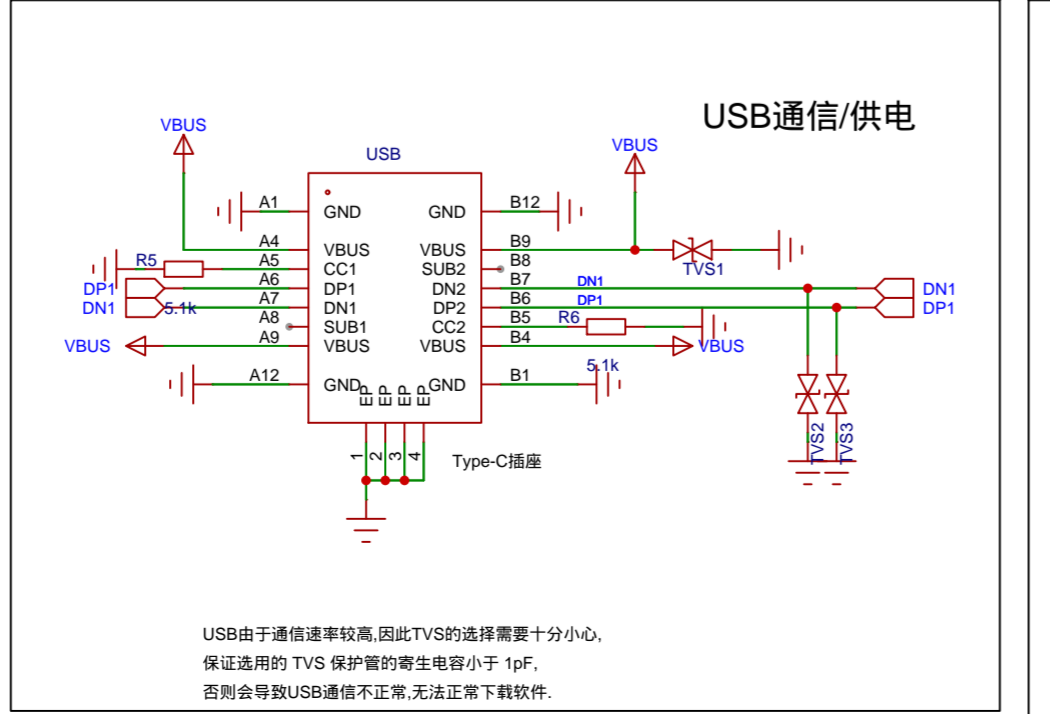
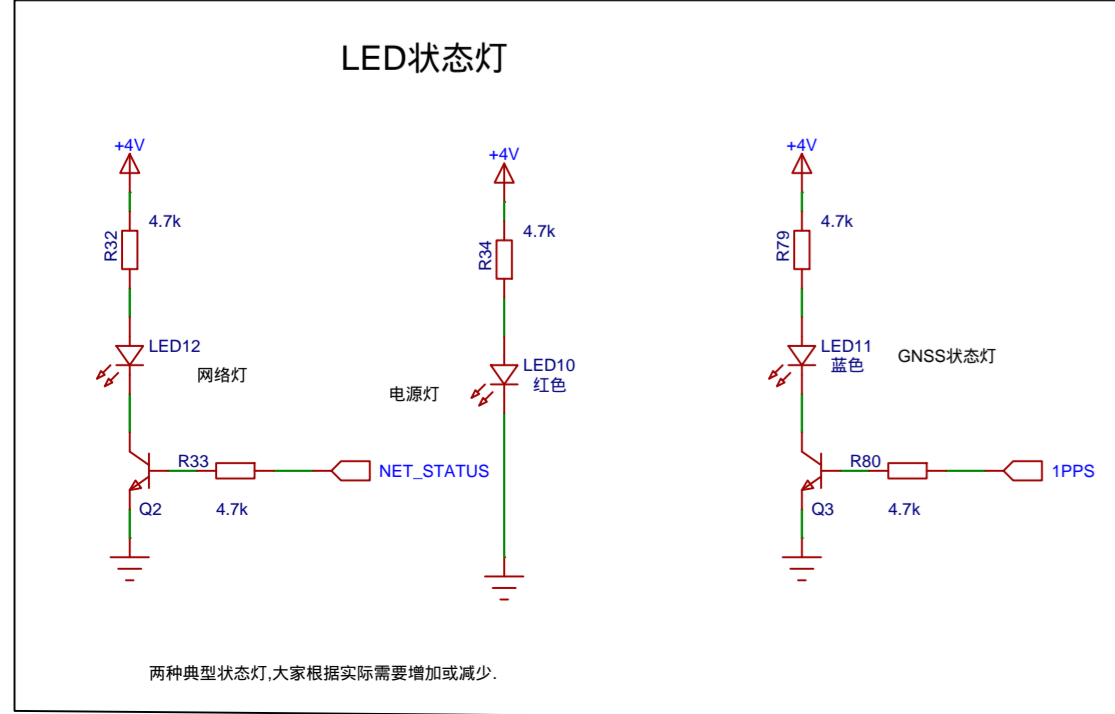
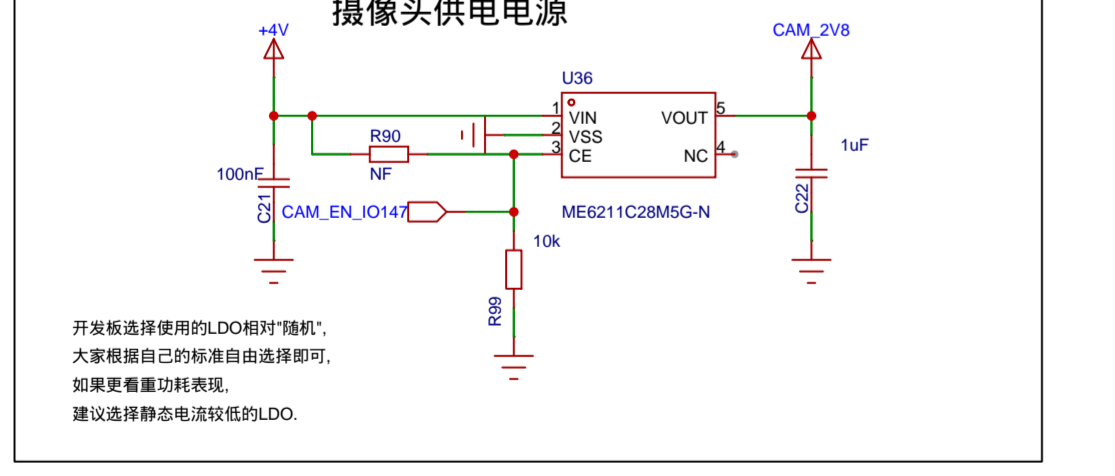
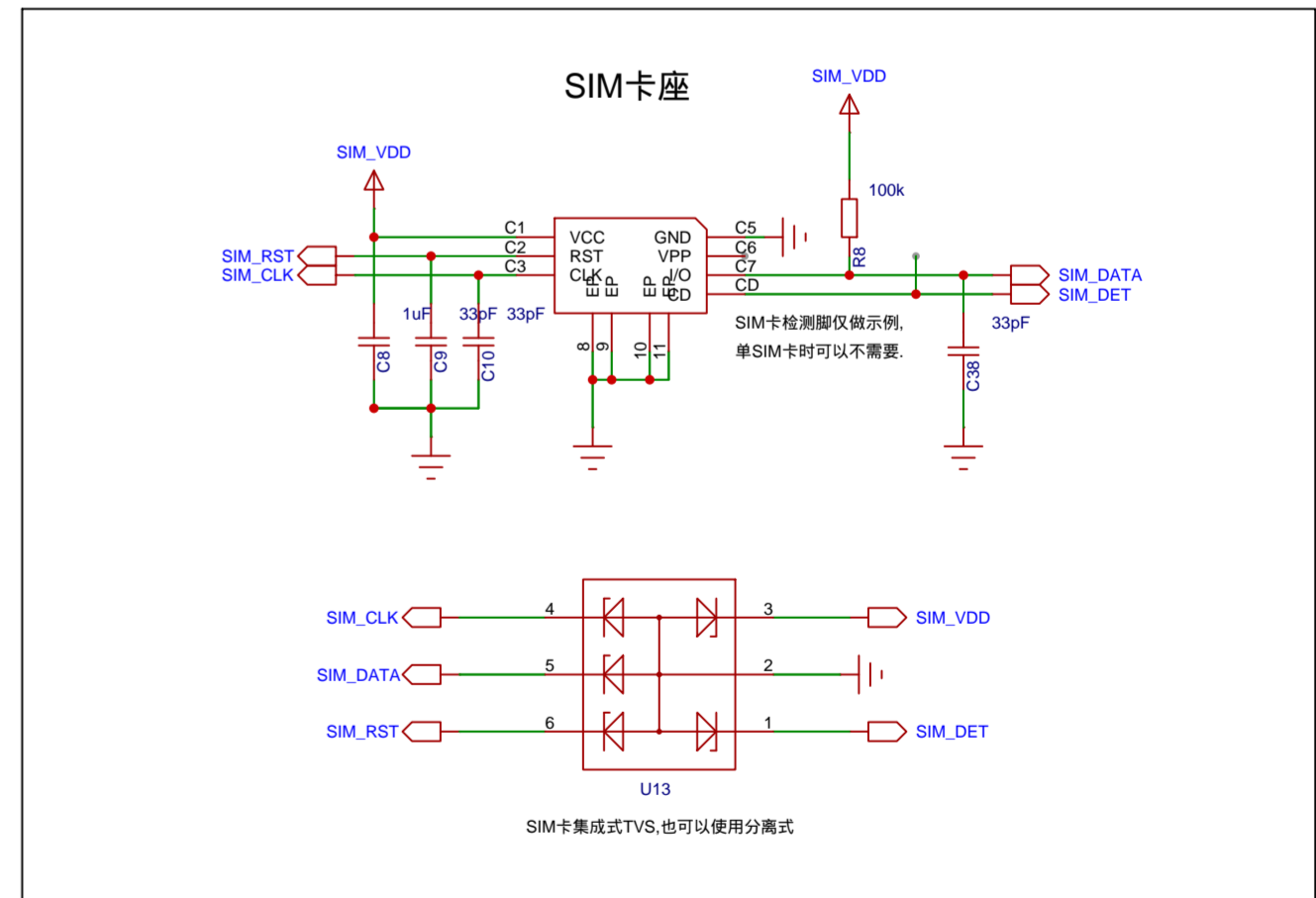
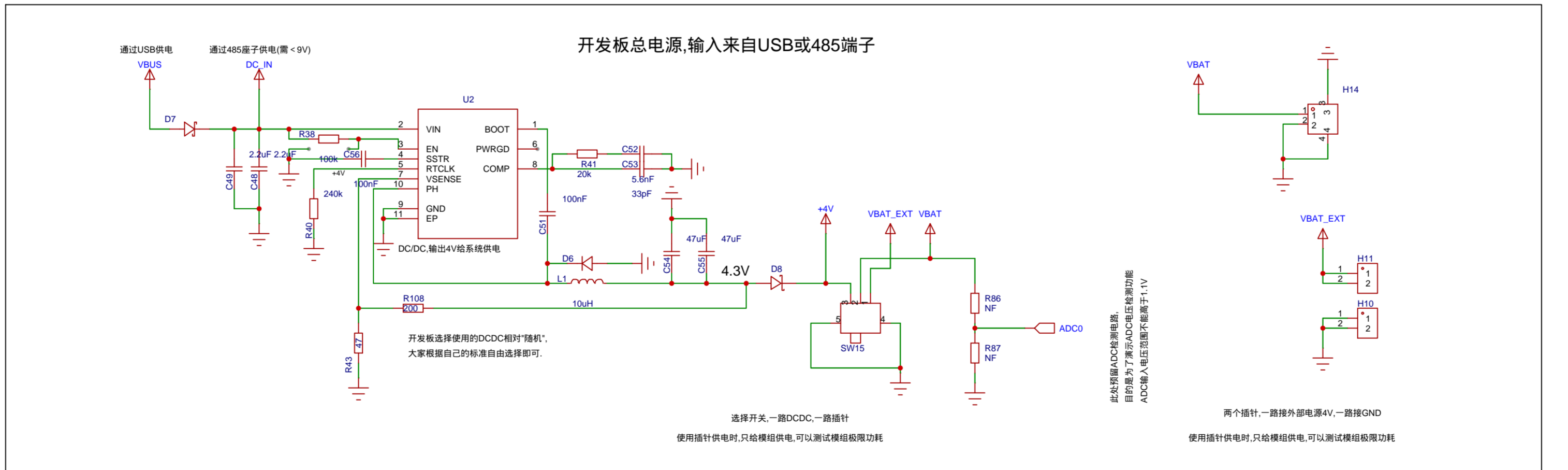
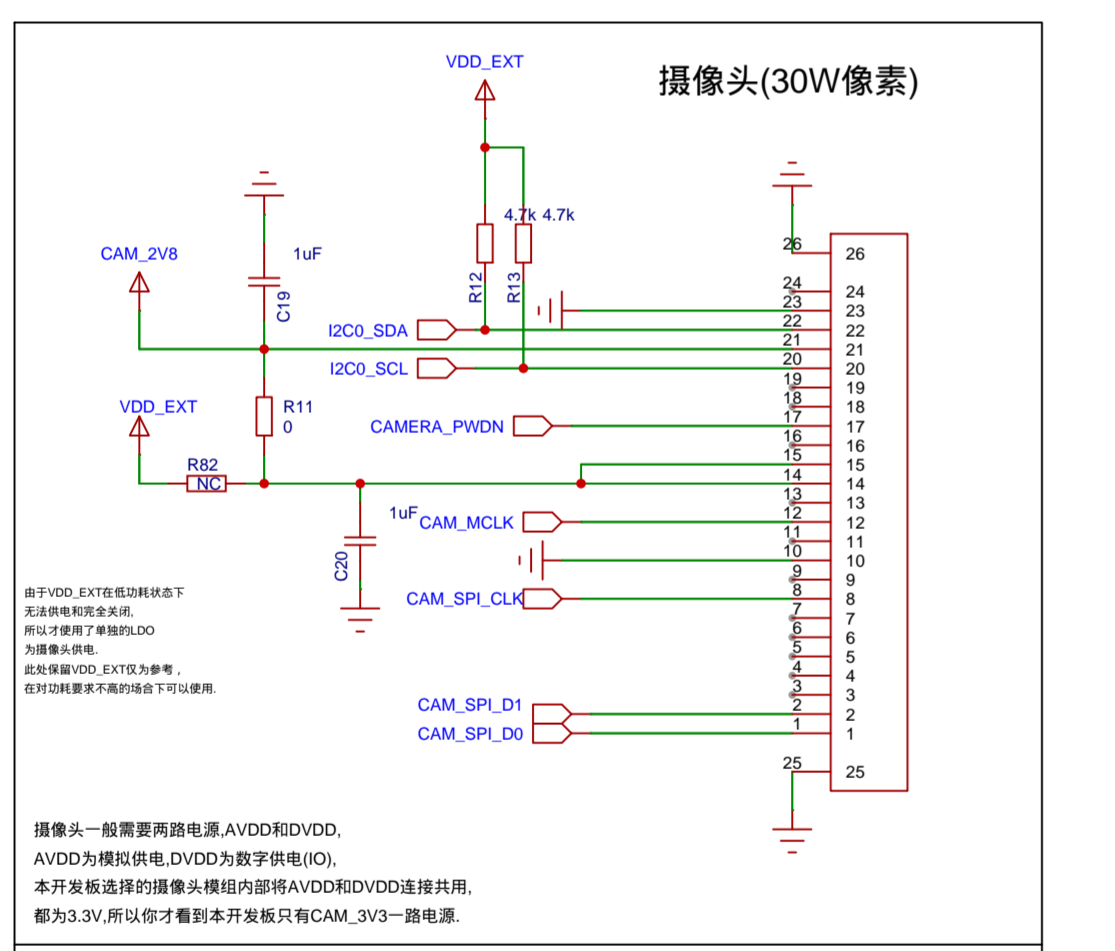
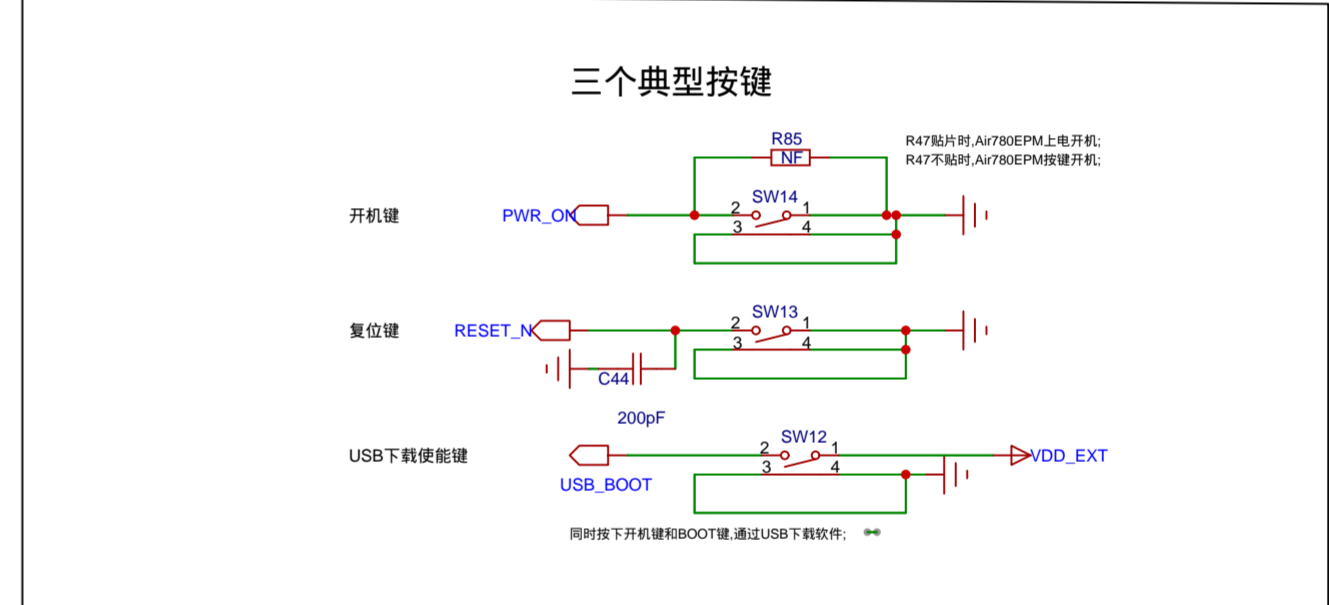
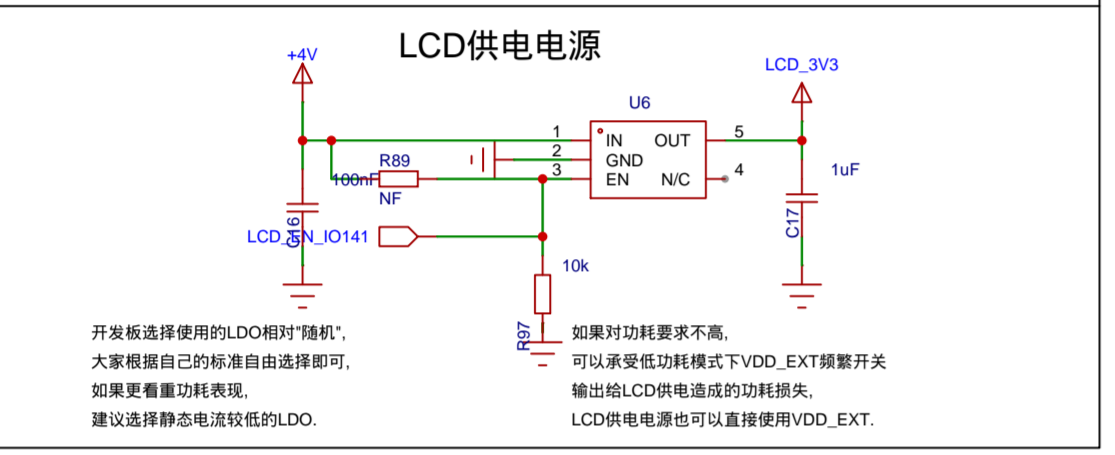
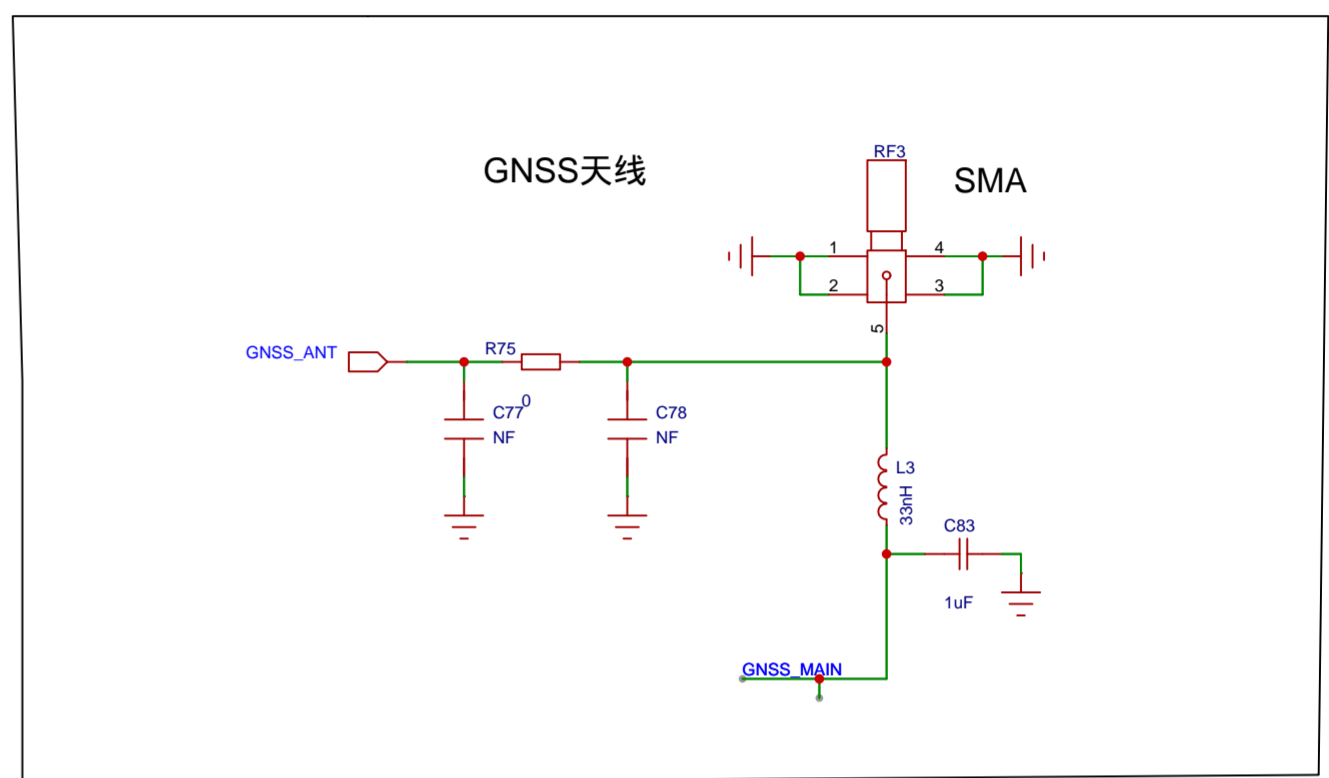
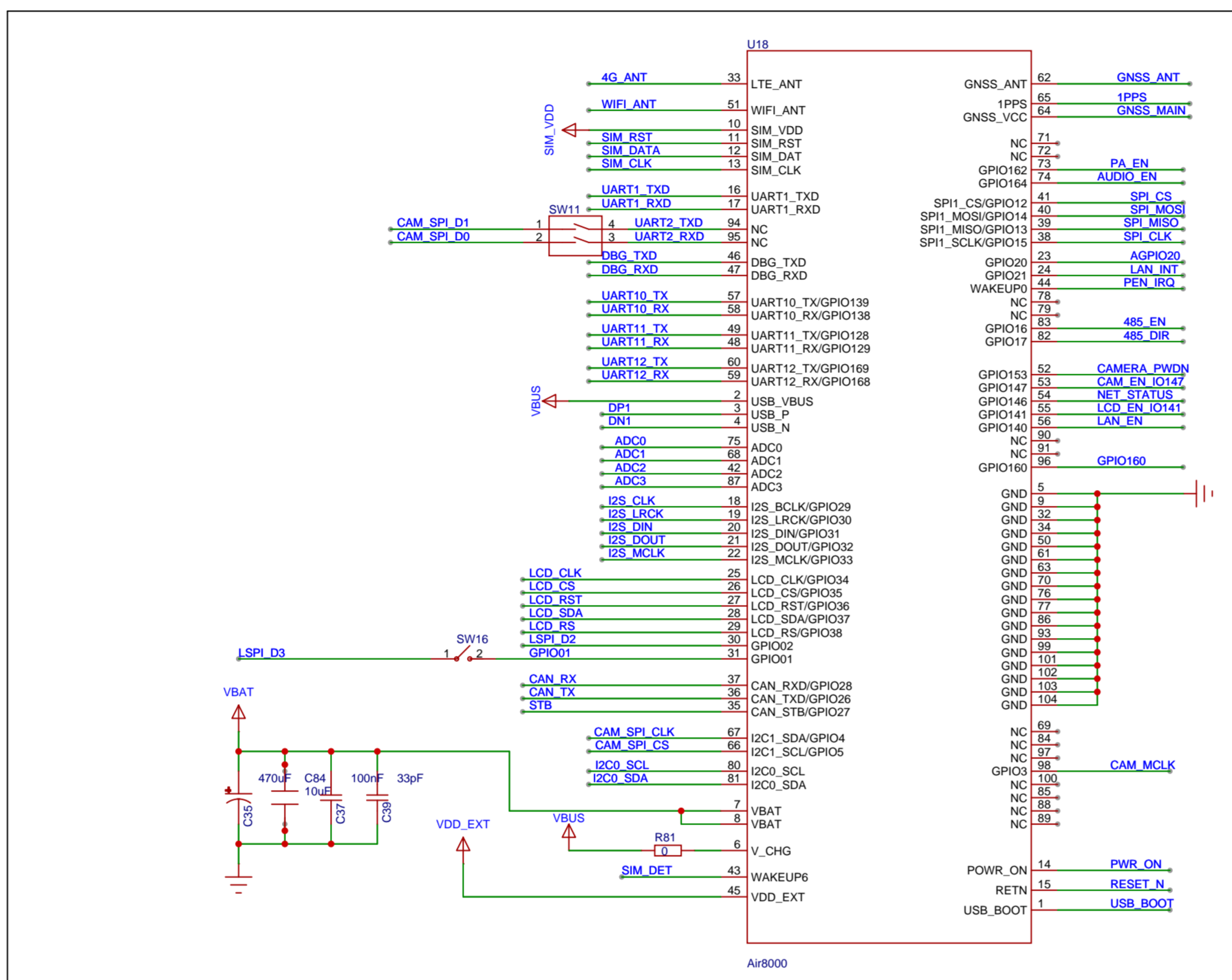
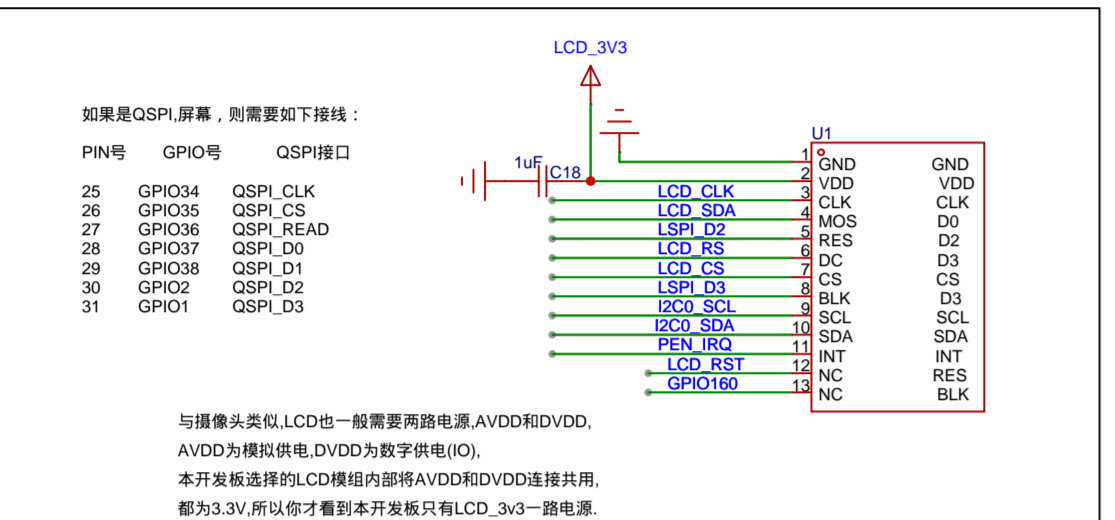
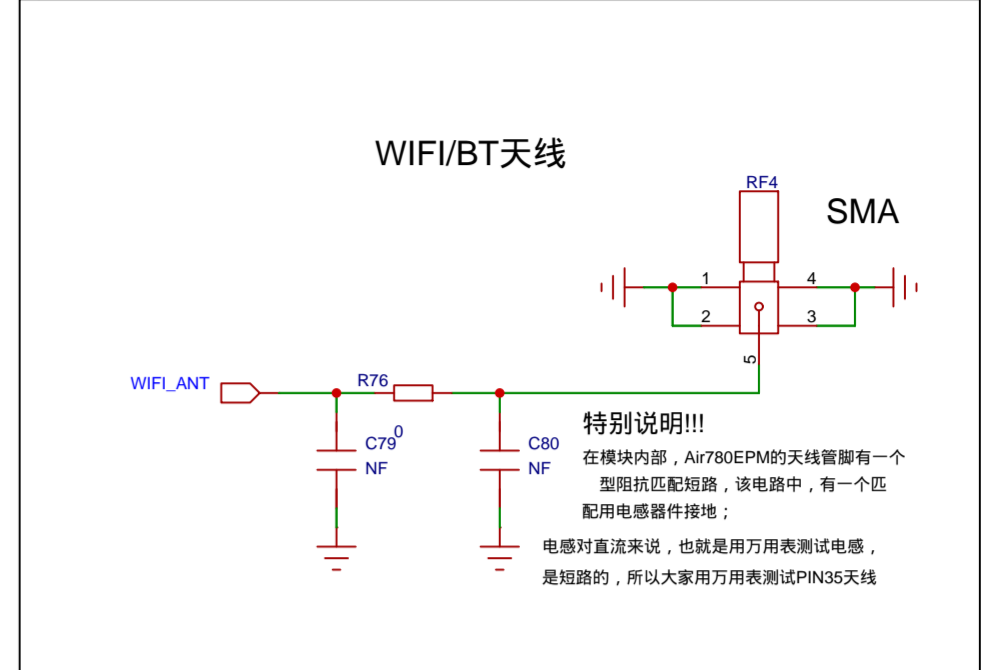
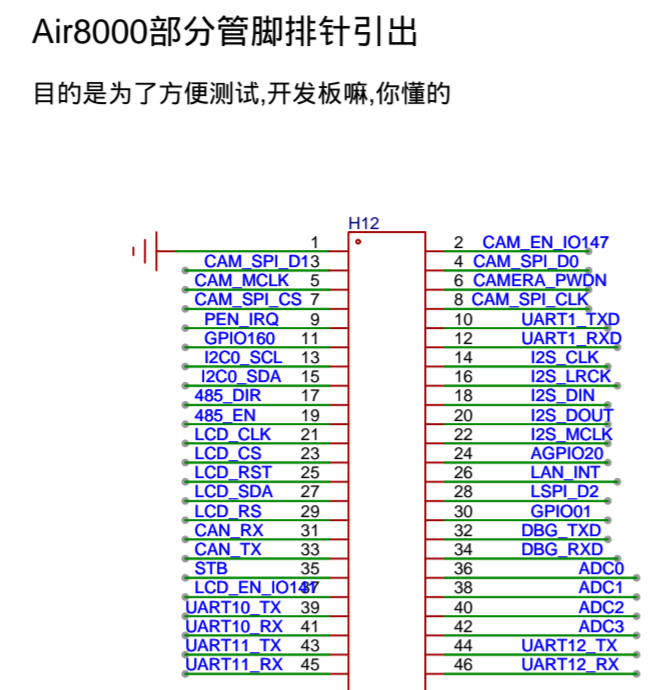
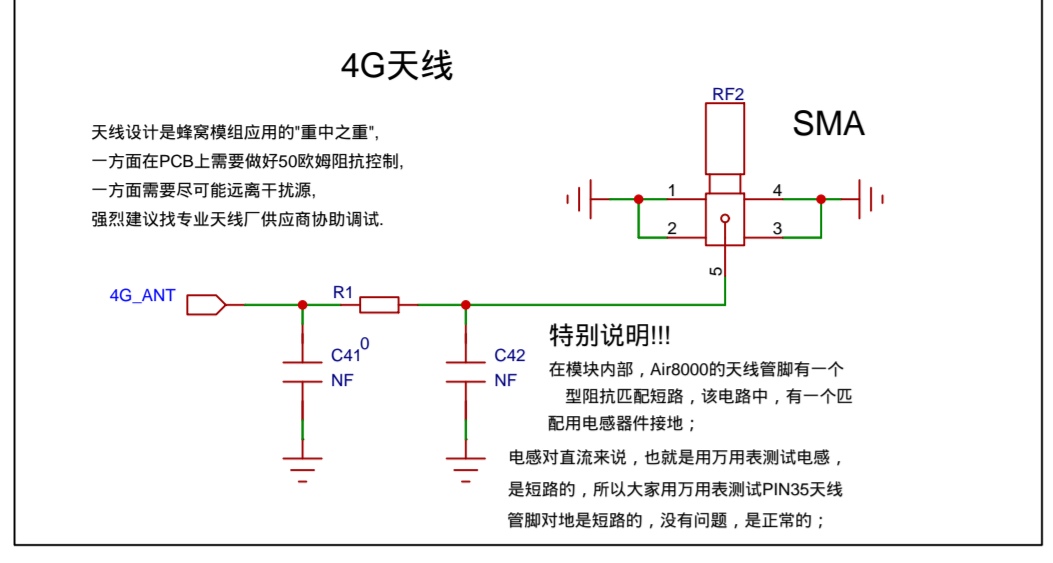

COMPANY:	合宙LuatOS		
TITLE:	Air8000开发板		
DRAWN:	ZhuPingjun	DATE:	2025-1-11
CHECKED:	liangjian	DATE:	2025-1-12
QUALITY CONTROL:	liangjian	DATE:	2025-1-12
RELEASED:	liangjian	DATE:	2025-1-12
CODE:	liangjian	SIZE:	A1
DRAWING NO:	2025-2-14	REV:	4
SCALE:	G	SHEET:	01 / 2

REVISION RECORD			
LTR	ECO NO.	APPROVED	DATE

CAN接口

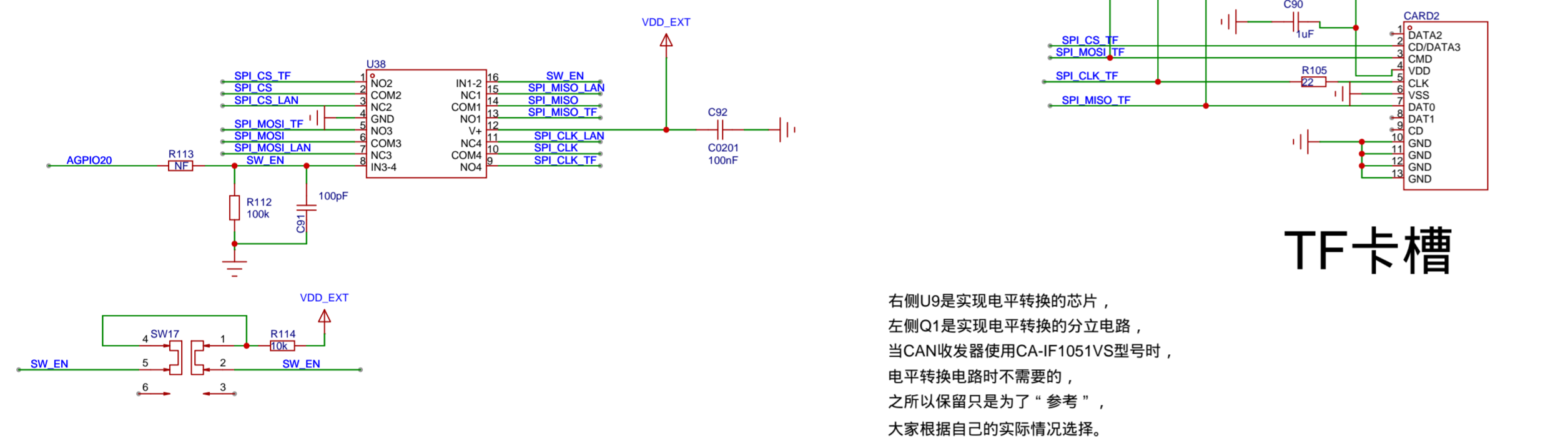
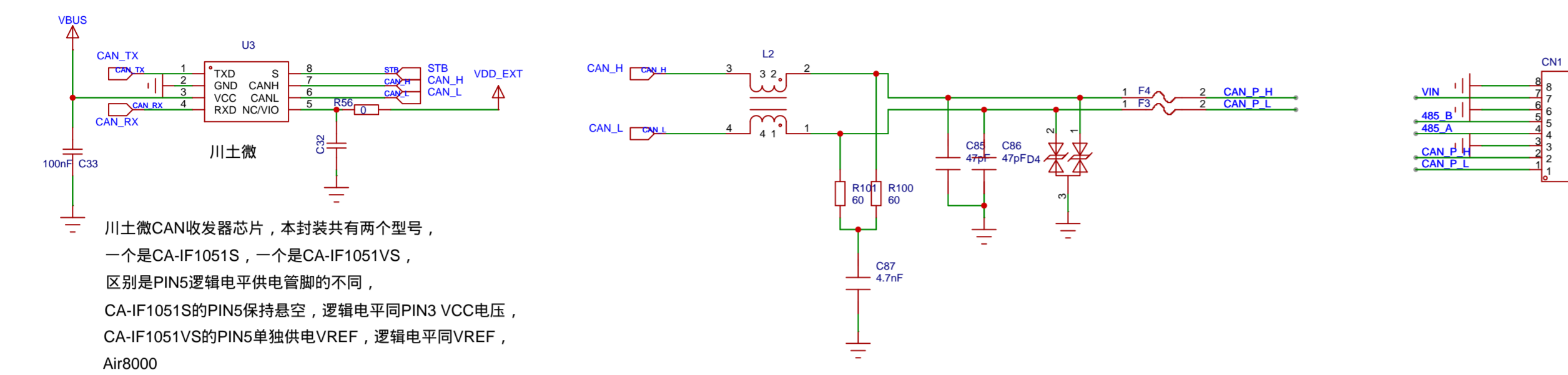

音频

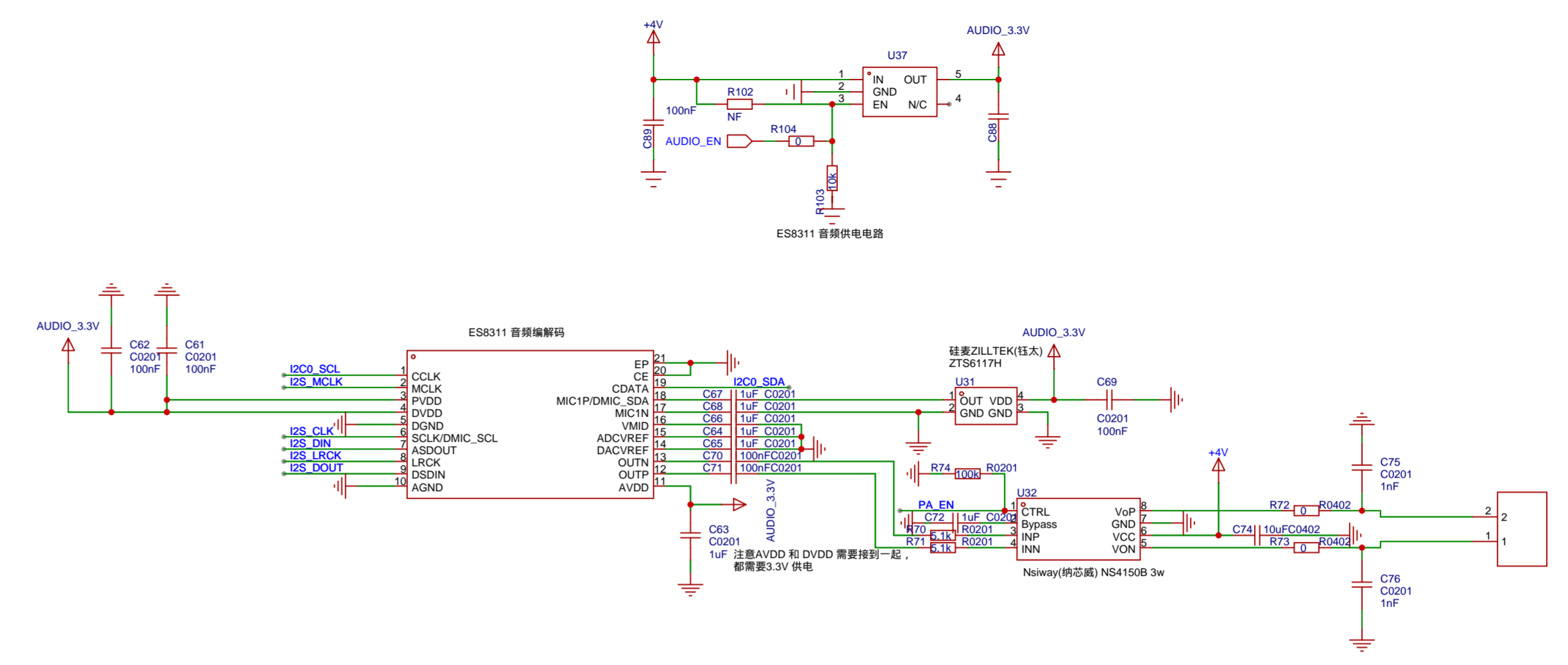

以太网RJ45网口

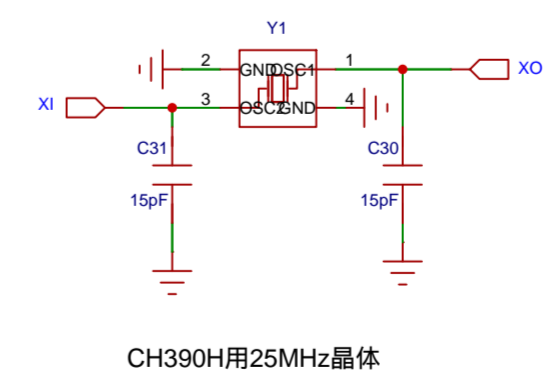
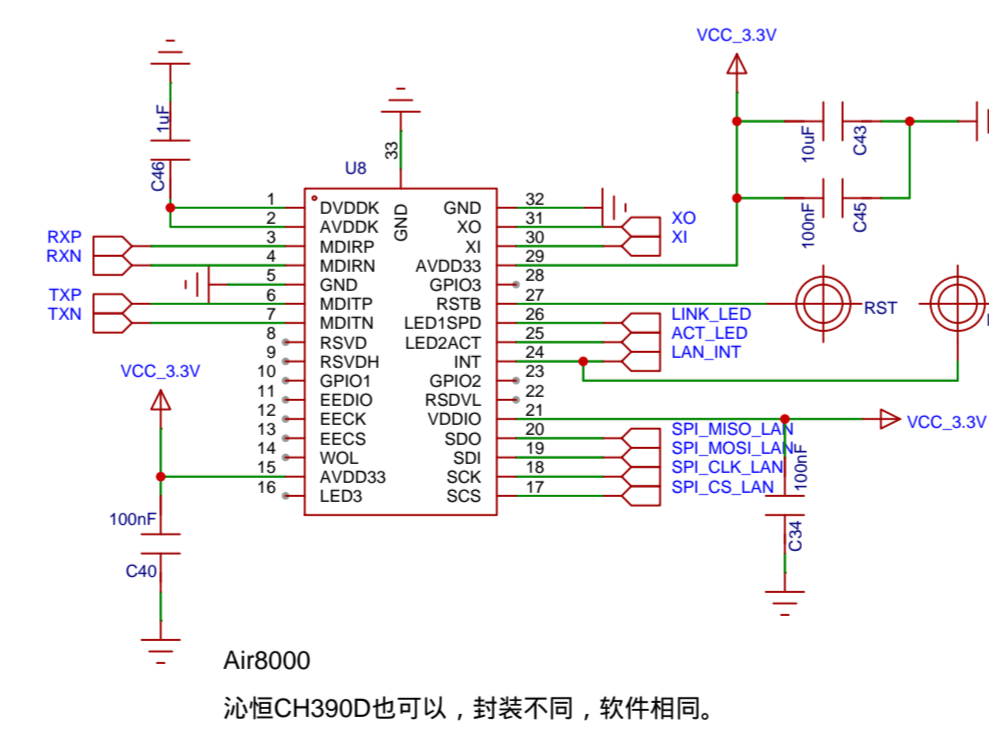
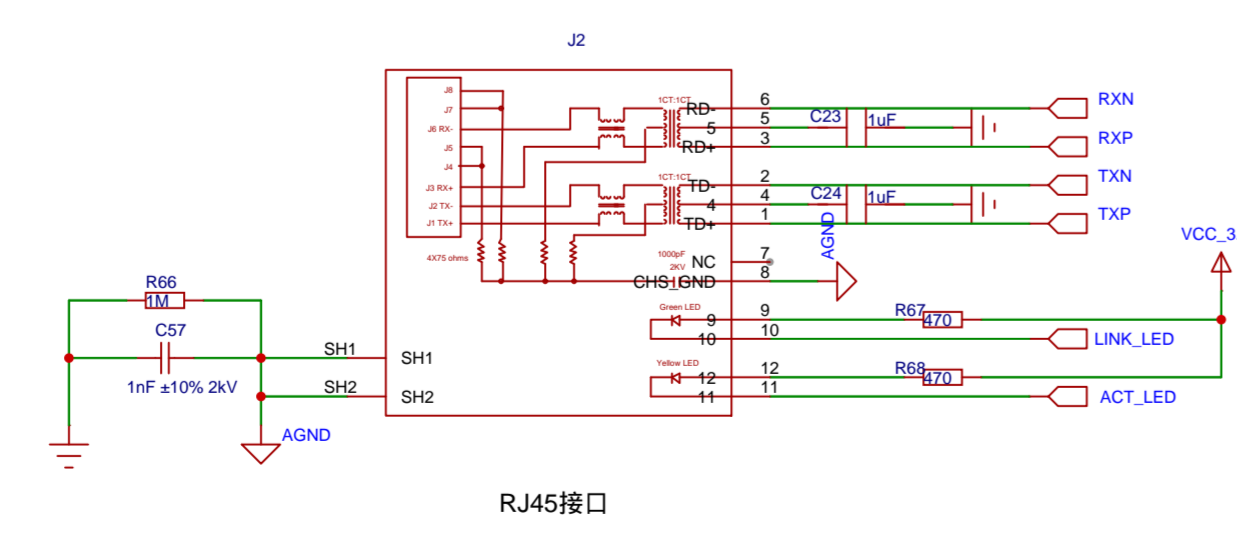
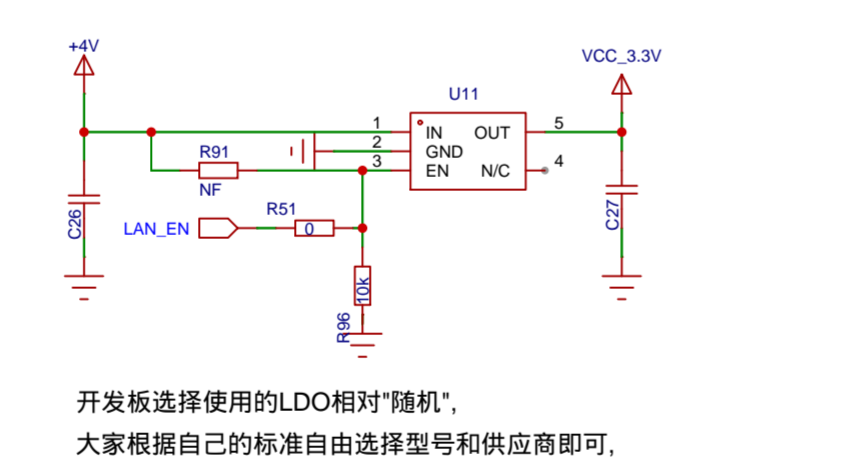

COMPANY:		合宙LuatOS	
TITLE:		Air8000开发板	
DRAWN:	ZhuPingjun	DATE:	2025-1-11
CHECKED:	liangjian	DATE:	2025-1-12
QUALITY CONTROL:	liangjian	DATE:	2025-1-12
RELEASED:	liangjian	DATE:	2025-1-12
CODE:	liangjian	SIZE:	A1
DRAWING NO:	2025-2-14	REV:	4
SCALE:	G	SHEET:	02 / 2