

Description

CSLS03FBZ is a low capacitance TVS (Transient Voltage Suppressor) designed to protect high speed data interfaces. It has been specifically designed to protect sensitive electronic components which are connected to data and transmission lines from over-stress caused by ESD (Electrostatic Discharge).

CSLS03FBZ may be used to provide ESD protection up to $\pm 30\text{kV}$ air and $\pm 30\text{kV}$ contact discharge according to IEC61000-4-2, and withstand peak pulse current up to 10A (8/20 μs) according to IEC61000-4-5.

Features

- Ultra small package: 1.0x0.6x0.5mm
- Low capacitance: 0.6pF
- Protects one data or power line
- Low operating voltage: 3.3V
- 2-pin leadless package
- Complies with following standards:
 - IEC 61000-4-2 (ESD) immunity test
 - Air discharge: $\pm 30\text{kV}$
 - Contact discharge: $\pm 30\text{kV}$
 - IEC61000-4-5 (Lightning) 10A (8/20 μs)
- RoHS Compliant

Dimensions and Pin Configuration

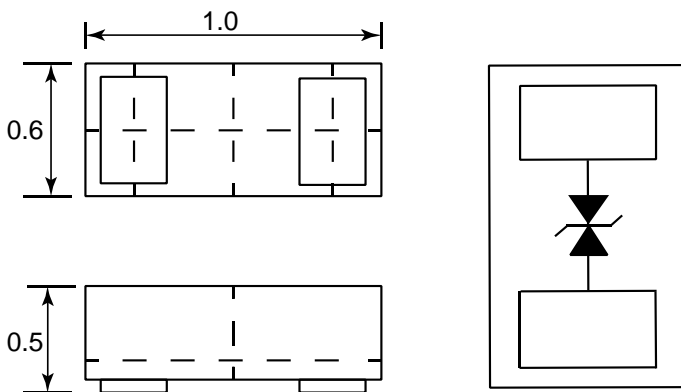

Package Dimensions

Circuit and Pin Schematic

Mechanical Characteristics

- Package: DFN1006-2 (1.0x0.6x0.5mm)
- Case Material: "Green" Molding Compound.
- Moisture Sensitivity: Level 1 per J-STD-020
- Marking Information: See Below

Applications

- USB 2.0 and USB 3.0
- HDMI 1.3, HDMI 1.4 and HDMI 2.0
- SATA and e SATA interface
- DVI
- IEEE 1394
- Portable Electronics and Notebooks

Marking Information

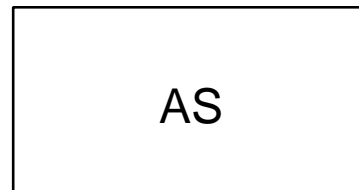

AS = Device Marking Code

Ordering Information

Part Number	Shipping	Reel Size
CSLS03FBZ	10000/Tape & Reel	7 inch

Absolute Maximum Ratings (T_A=25°C unless otherwise specified)

Parameter	Symbol	Value	Unit
Peak Pulse Power (8/20μs)	P _{PK}	50	W
Peak Pulse Current (8/20μs)	I _{PP}	10	A
ESD per IEC 61000-4-2 (Air)	V _{ESD}	±30	kV
ESD per IEC 61000-4-2 (Contact)		±30	
Lead temperature	T _L	260	°C
Operating Temperature Range	T _{OP}	-40 ~ +85	°C
Storage Temperature Range	T _{STG}	-55 ~ +150	°C

Electrical Characteristics (T_A=25°C unless otherwise specified)

Parameter	Symbol	Min	Typ	Max	Unit	Test Condition
Reverse Working Voltage	V _{RWM}			3.3	V	
Punch-Through Voltage	V _{PT}	3.5			V	I _T = 2μA
Snap-Back Voltage	V _{SB}	0.8			V	I _T = 50mA
Reverse Leakage Current	I _R			0.2	μA	V _{RWM} = 3.3V
Clamping Voltage	V _C		4		V	I _{PP} = 1A (8/20μs pulse)
Clamping Voltage	V _C		5		V	I _{PP} = 10A (8/20μs pulse)
Junction Capacitance	C _J		0.6		pF	V _R = 0V, f = 1MHz

Electrical characteristics ($T_A = 25^\circ\text{C}$, unless otherwise noted)

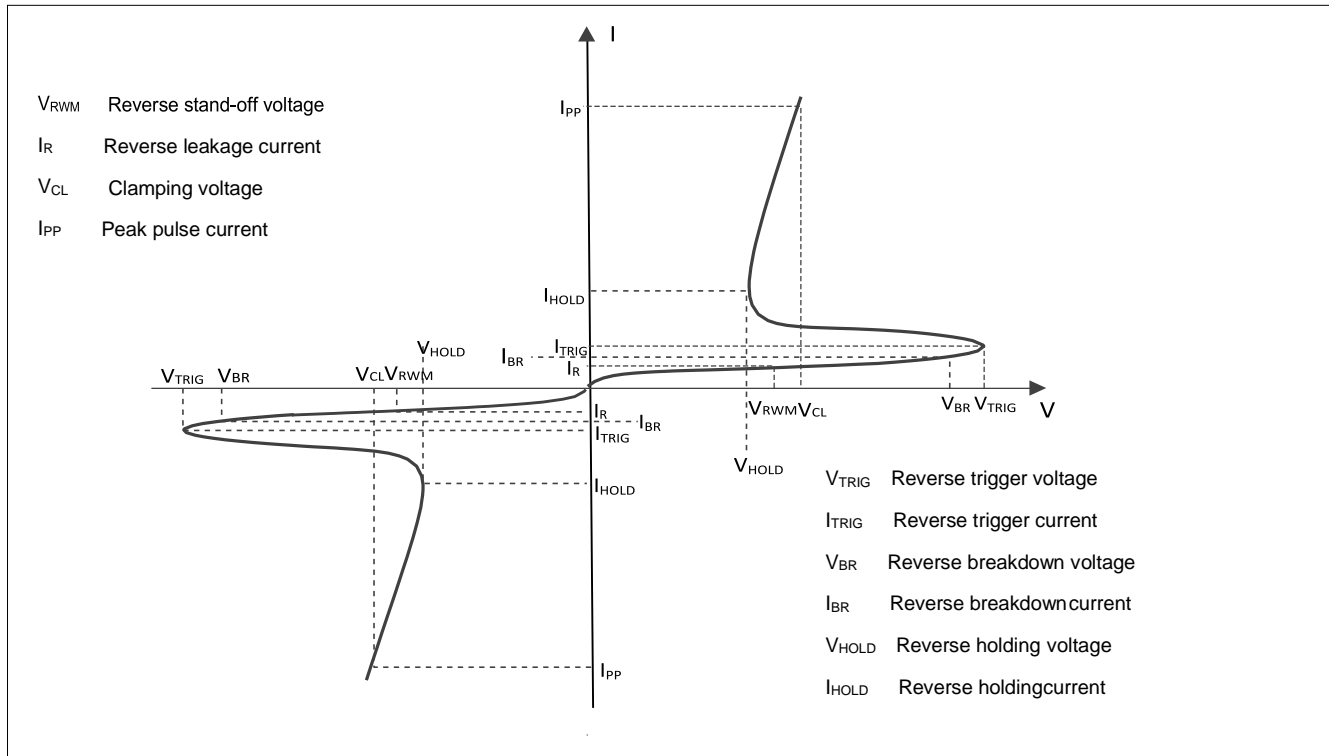

Definitions of electrical characteristics

Typical Performance Characteristics ($T_A=25^\circ\text{C}$ unless otherwise Specified)

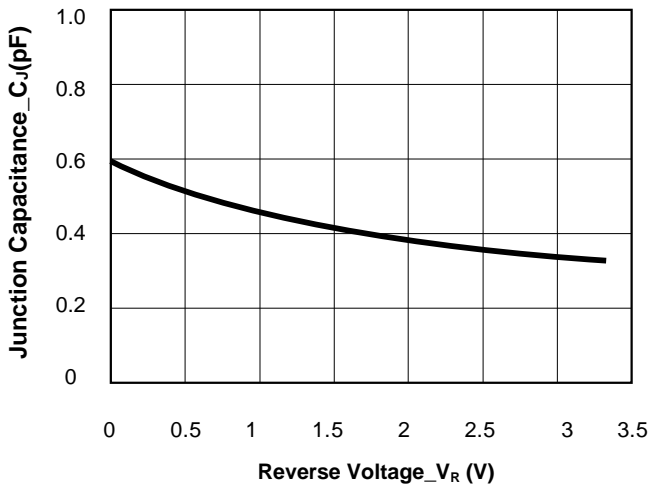

Junction Capacitance vs. Reverse Voltage

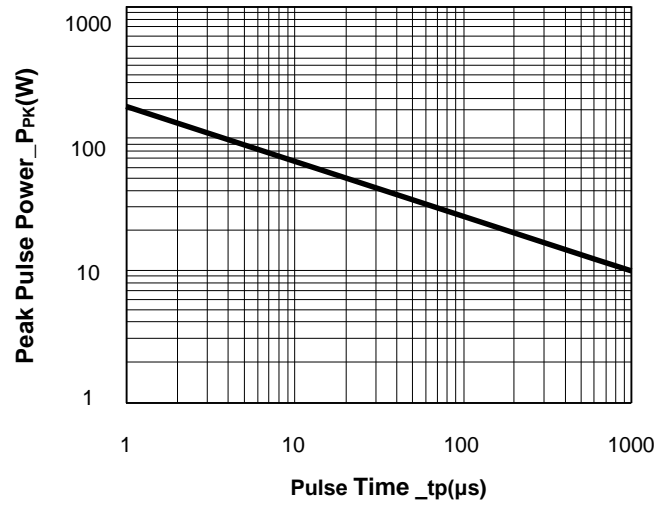

Peak Pulse Power vs. Pulse Time

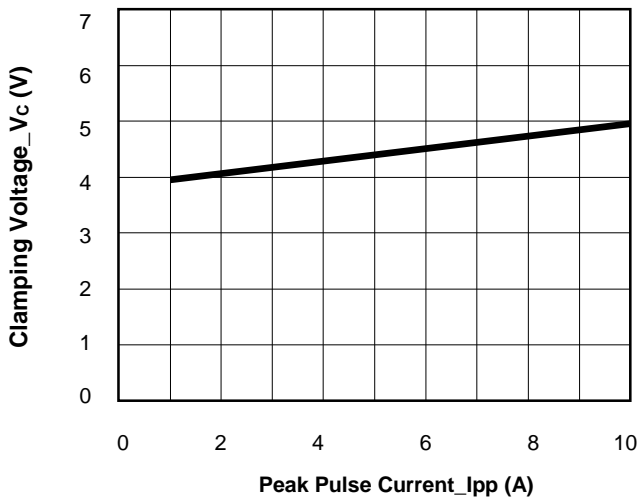

Clamping Voltage vs. Peak Pulse Current

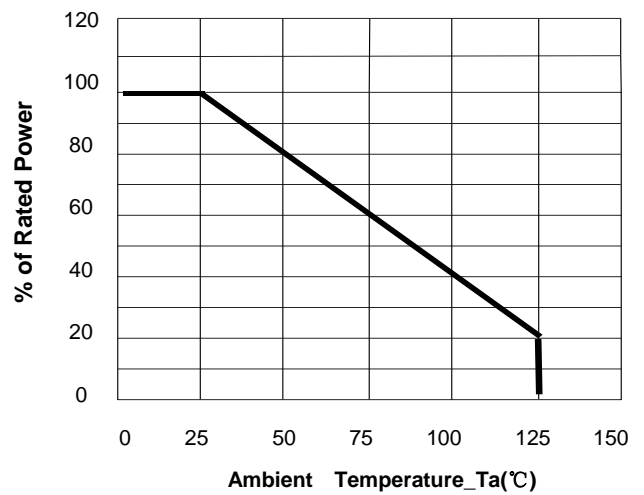

Power Derating Curve

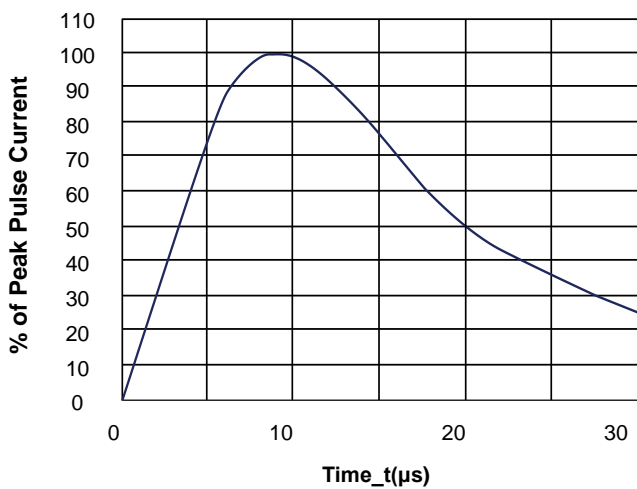

8/20 μs Pulse Waveform

DFN1006-2 Package Outline Drawing

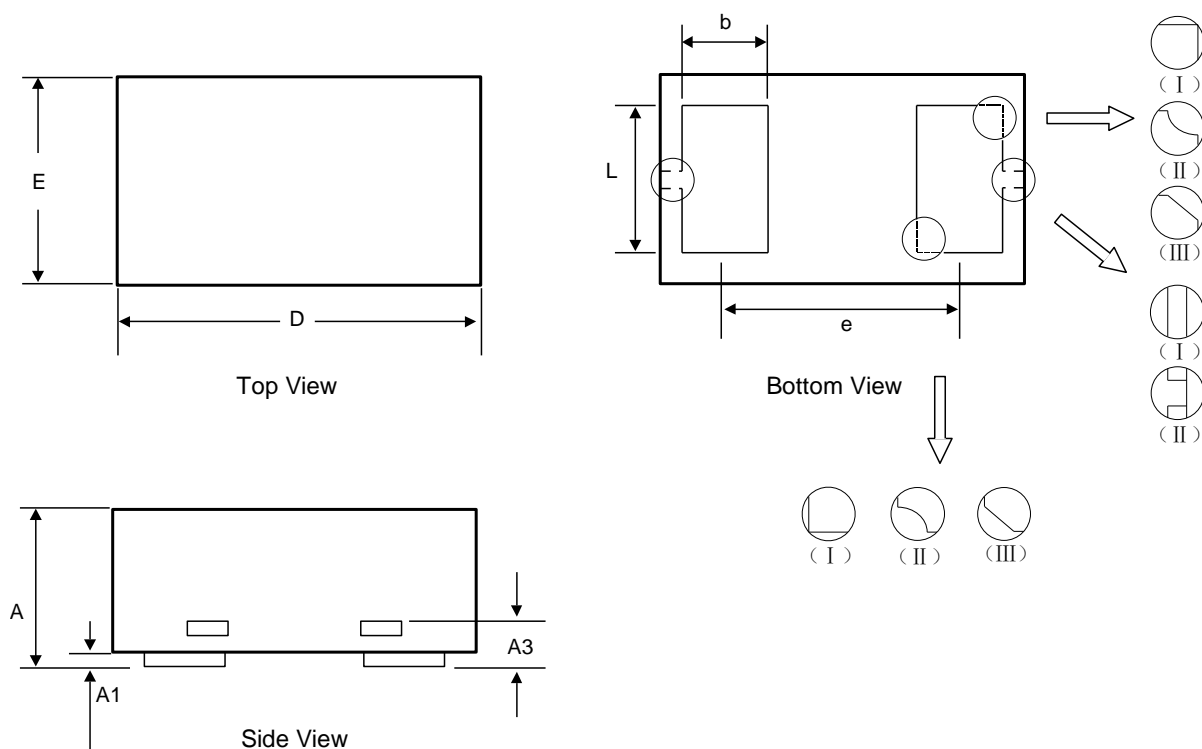

Symbol	Dimensions in Millimeters		
	Min.	Typ.	Max.
A	0.340	0.450	0.550
A1	0.000	0.020	0.050
A3	0.125 Ref.		
D	0.950	1.000	1.075
E	0.490	0.600	0.675
b	0.200	0.250	0.300
L	0.450	0.500	0.550
e	0.650 BSC		

Recommended PCB Layout (Unit: mm)

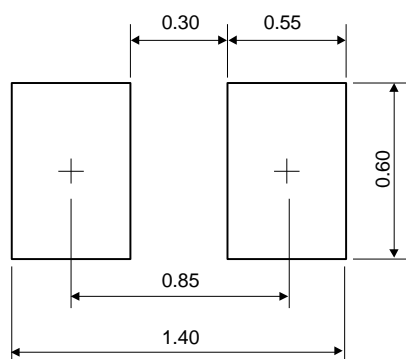

Notes:

This recommended land pattern is for reference purposes only. Please consult your manufacturing group to ensure your PCB design guidelines are met.

TAPE AND REEL INFORMATION

Reel Dimensions

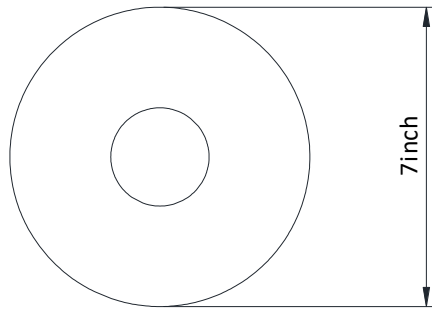

Tape Dimensions

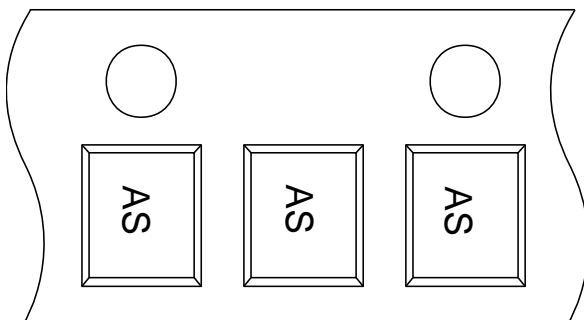
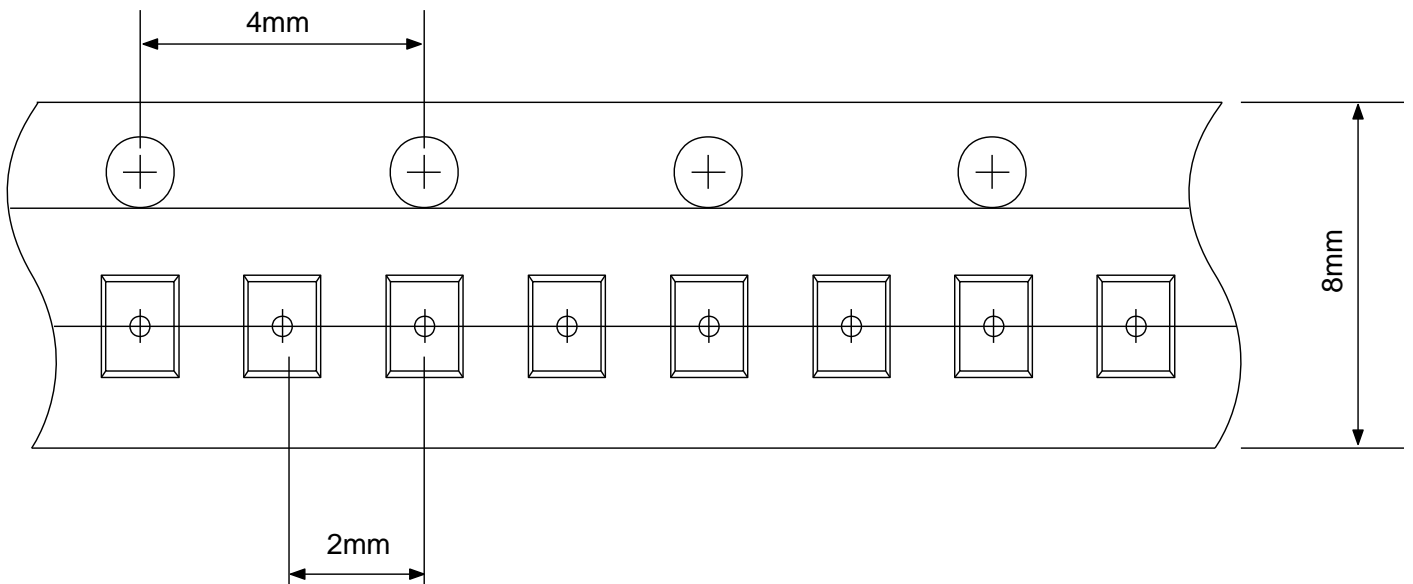

User Direction of Feed

Revision history of Specification

Version	Change Items	Effective Date
1.0	Initial Release	10-Nov-2022